

STEP-1

PLEASE CAREFULLY READ ALL OF THE INSTRUCTIONS PRIOR TO INSTALLATION

The KLX2-P2 is designed to fit both right-hand and left-hand applications. To conform to your application the latch and button assembly may need to be reversed.

- To reverse the latch assembly: remove the four screws holding the mounting base, carefully lift and rotate the mounting base 180° (Fig #1) and fasten with provided hardware.
IMPORTANT: INNER COMPONENTS MUST NOT BE DISTURBED WHILE REVERSING THE ASSEMBLY.

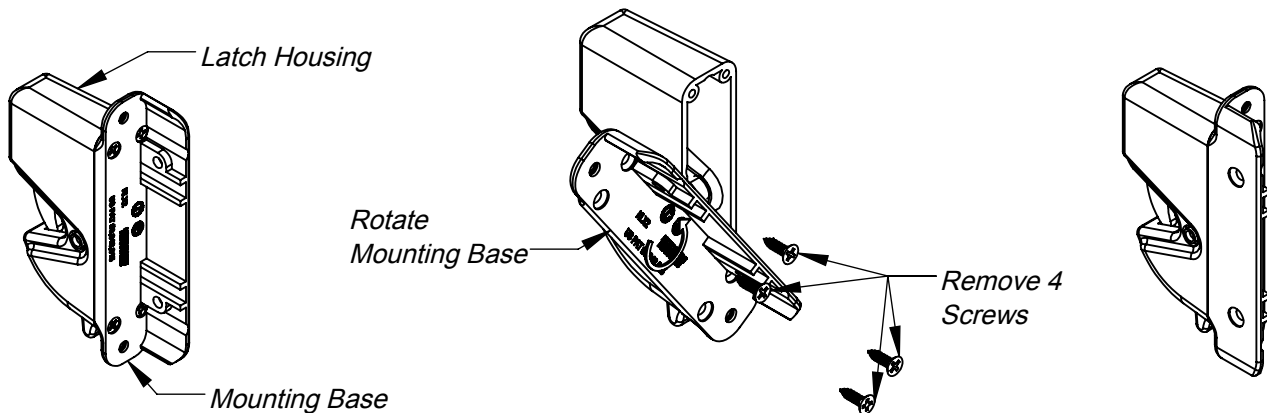

**FIG. #1
Latch Assembly**

- To reverse the button assembly: remove the four screws, mounting base, spring, and spindle from the button as shown (Fig #2). Rotate the mounting base and spindle 180°. Reinstall components in the reverse order, (reverse order of Fig #2), to insure proper functionality: 1. Slide spindle in the provided slot of the button (Refer to **Step 2** if spindle must be cut) 2. Insert spring into the bent portion of the spindle and place inside rear of button. Make sure the spring seats on mounting base spring bump (not shown) and rests against the spindle 3. Finally, insert mounting base (make sure spindle slides through provided slot of the mounting base) and fasten with provided hardware.
IMPORTANT: INNER COMPONENTS MUST NOT BE DISTURBED WHILE REVERSING THE ASSEMBLY.

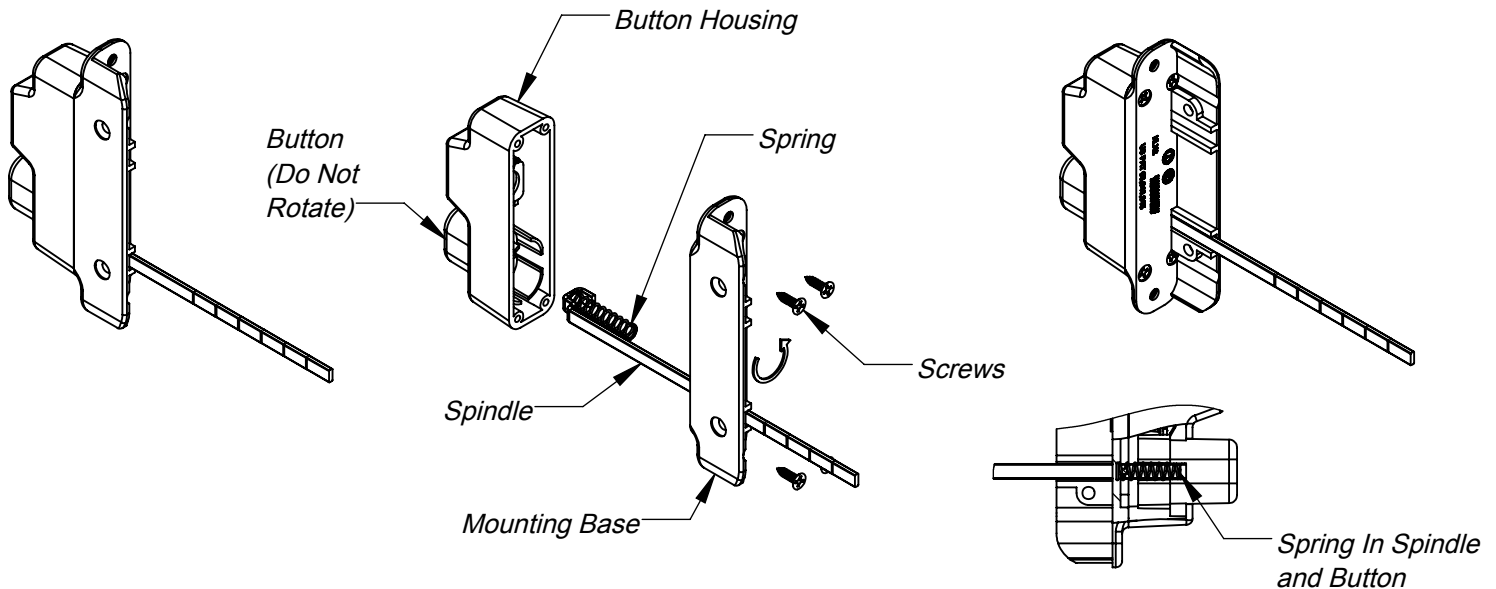

**FIG. #2
Button Assembly**

STEP-2

Depending on the fence post size of your application the spindle may have to be cut, a chart has been provided below.

IMPORTANT: BE CAREFUL TO AVOID BENDING SPINDLE DURING CUTTING PROCESS.

Spindle Cutting Table	
Post Thickness	Cut Location on Spindles
2	Cut at the Sixth Inscribed Cut Mark
3	Cut at the Fourth Inscribed Cut Mark
3-1/2	Cut at the Third Inscribed Cut Mark
4	Cut at the Second Inscribed Cut Mark
5	DO NOT CUT SPINDLE

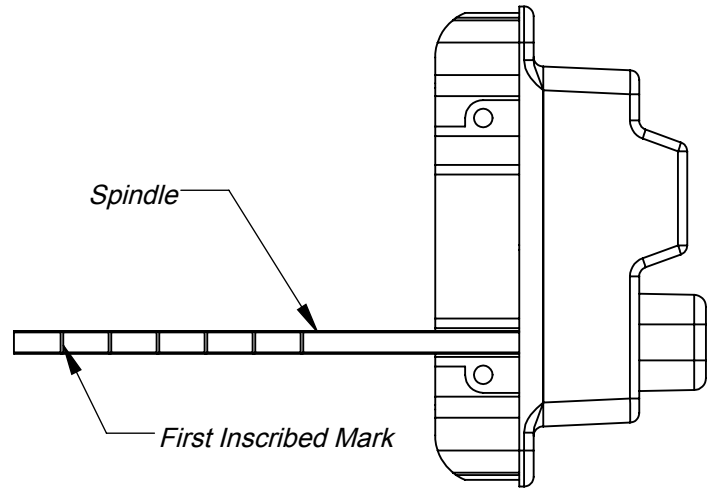

**FIG. #3
Button Assembly Spindle Cut Marks**

STEP-3

Locate latch assembly at the desired height on the fence post, mark the centerpoints of the mounting holes, and drill appropriate pilot holes for mounting screws. Insert spindle of button assembly into the provided slot of the mounting base of latch assembly and align to make sure spindle is properly inserted and leveled. Mark the centerpoints of the mounting holes, and drill appropriate pilot holes for mounting screws (Fig #4).

STEP-4

After installing the latch and button assembly, with the gate closed, position and attach the striker with the striker rod within the latch assembly behind the latch mechanism and mark the centerpoints of the mounting holes, and drill appropriate pilot holes for mounting screws (Fig #5). After installation, **TEST** the locking and unlocking mechanism of the latch from both sides.

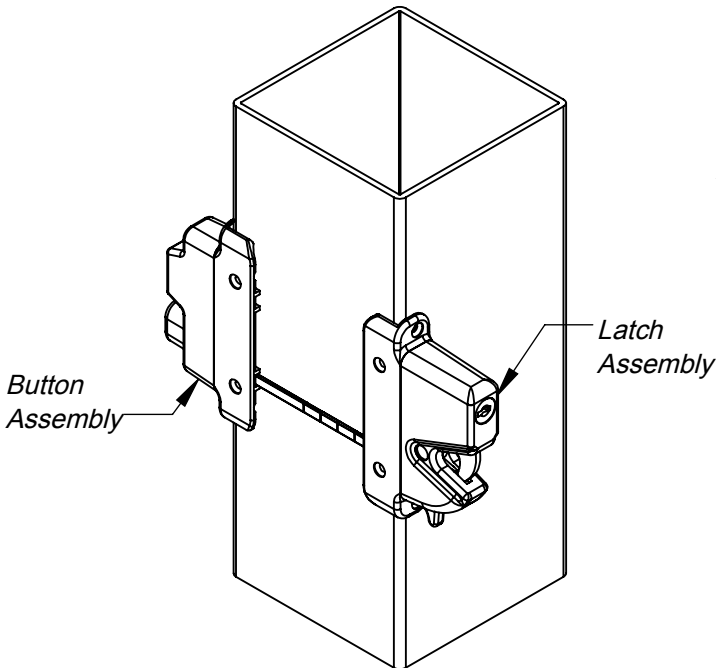

**FIG. #4
KLX2 on Post**

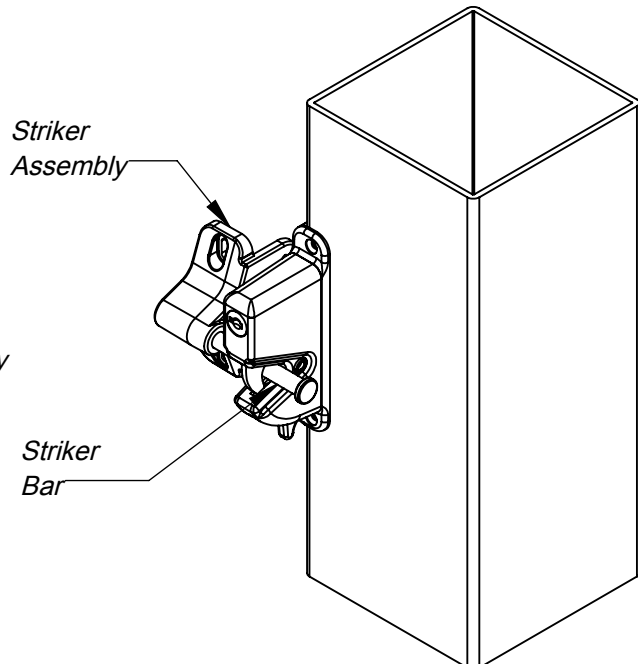

**FIG. #5
Striker Assembly**