

**NOTE: MAX GATE SIZE: 72" X 72"
MIN GATE SIZE: 36" X 48"**

STEP 1

Insert the 3/8" X 1.25" Bolt through the center hole of one Corner Bracket and through the Mount Hole of the Inner Tube, then secure with an Acorn Nut (Fig 1).

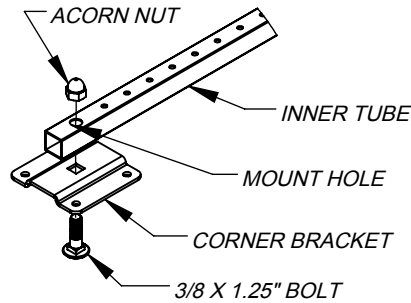

FIGURE 1

STEP 2

Align the Corner Bracket with the bottom corner of the Gate on the Hinge Side, with the Inner Tube pointing straight upward, and mount to the Gate using (4) #14 X .75" Screws (Fig 2).

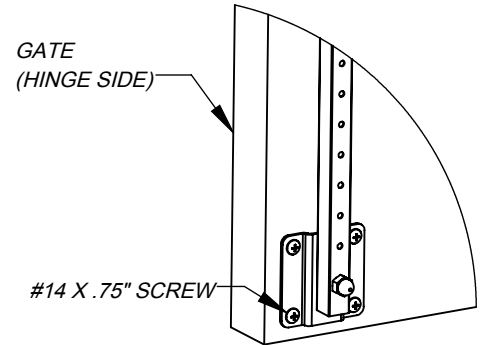

FIGURE 2

STEP 3

Insert the 3/8" X 1.5" Bolt through the center hole of the second Corner Bracket and through the Mount Hole of the Outer Tube (Fig 3).

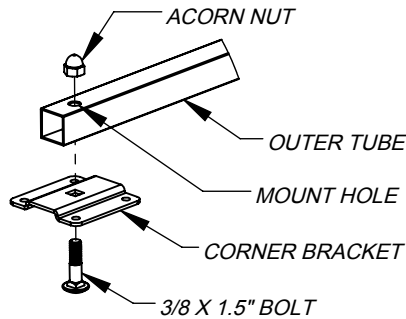

FIGURE 3

STEP 4

Place the Outer Tube over the Inner Tube, with Corner Brackets facing the same direction. Position the Corner Bracket from Step 3 at the top corner of the Gate on the Latch Side, making sure that the two Alignment Holes of the Outer Bracket line up with two Alignment Holes of the Inner Bracket (Fig 4 and 5). The angle between the Gate Brace and the Ground must be AT LEAST 45 degrees. Mark the location of the Bracket at this position.

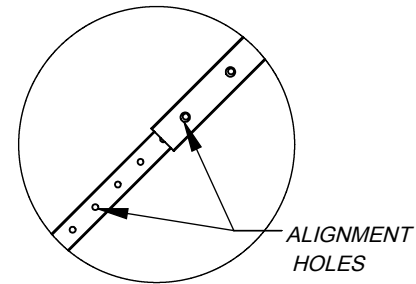

FIGURE 4

STEP 5

Remove the Corner Bracket/Bolt from the Outer Tube, and mount the Corner Bracket/Bolt at the marked location using (4) #14 X .75" Screws. Place the Mount Hole of the Outer Tube over the Bolt and secure with an Acorn Nut (Fig 5).

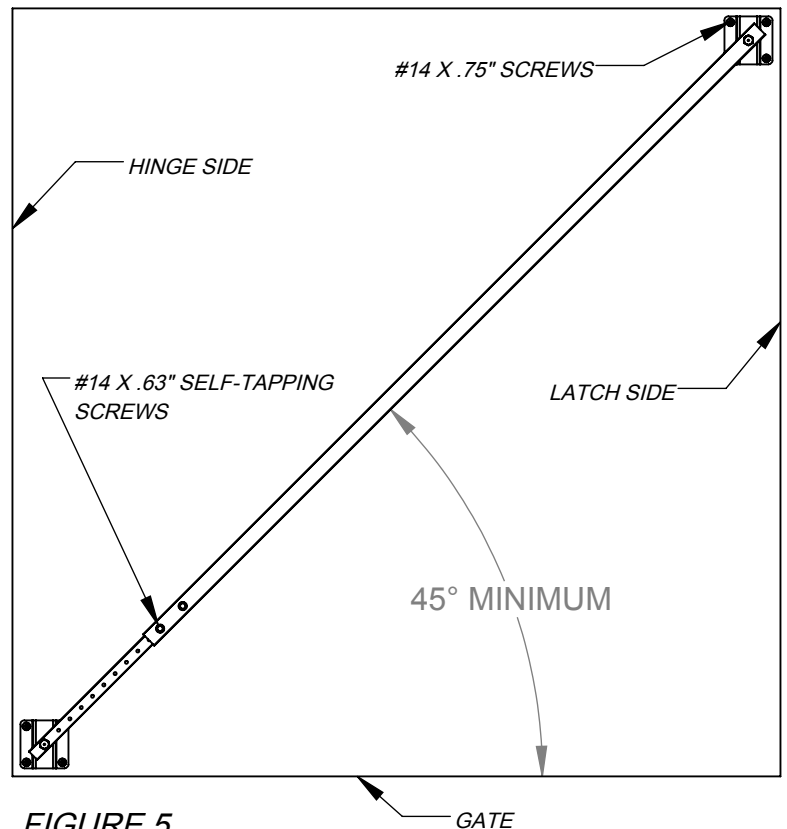

FIGURE 5

STEP 6

With the two Adjustment Holes of the Outer Bracket aligned with two Adjustment Holes of the Inner Bracket, secure the brackets together using (2) #14 X .63" Self-Tapping Screws (Fig 5).