

GW3 CHAIN LINK GATE WHEEL



SCAN FOR MORE
INFORMATION

MOUNTING INSTRUCTIONS:

1. Locate Gate Wheel assembly on gate as required. Loosely install the supplied U-bolts, lockwashers and nuts (Fig. 2 & 3).
2. Press down on bracket to compress the spring a minimum of 1/4" (Fig. 1).
3. Making sure the spring is compressed and the Gate Wheel is located correctly, tighten the nuts and lockwashers to the U-bolts to secure the Gate Wheel to the gate (Fig. 2 & 3).
4. When the gate wheel is located as desired, insert supplied self-drilling hex head set screw (Fig. 3).
5. Open and close gate to ensure Gate Wheel operates smoothly.

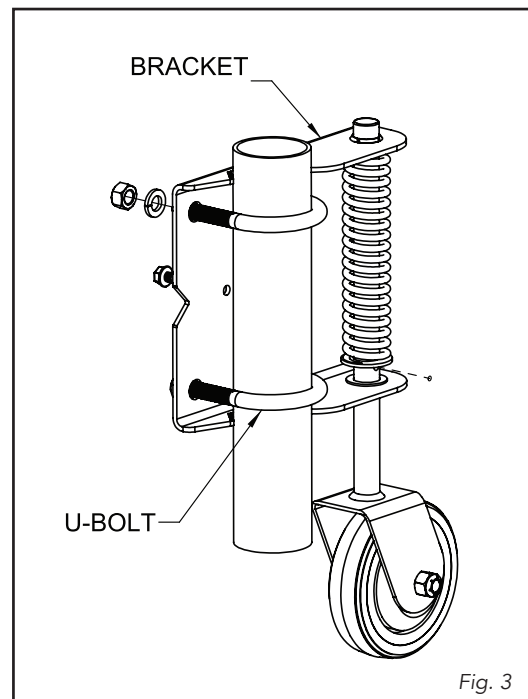
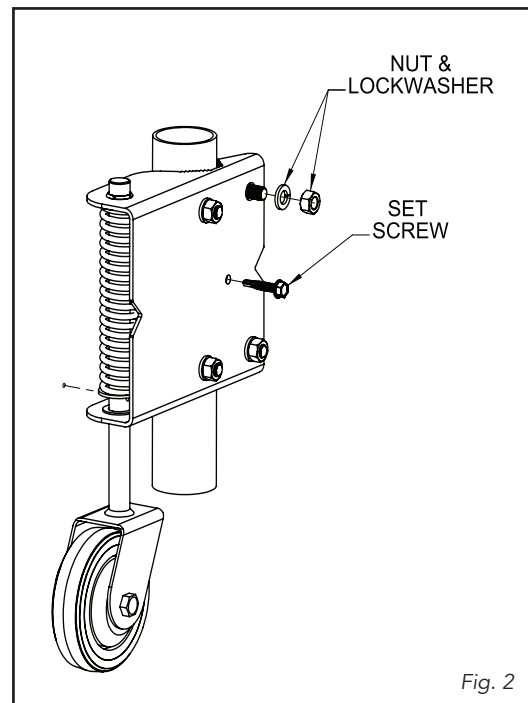
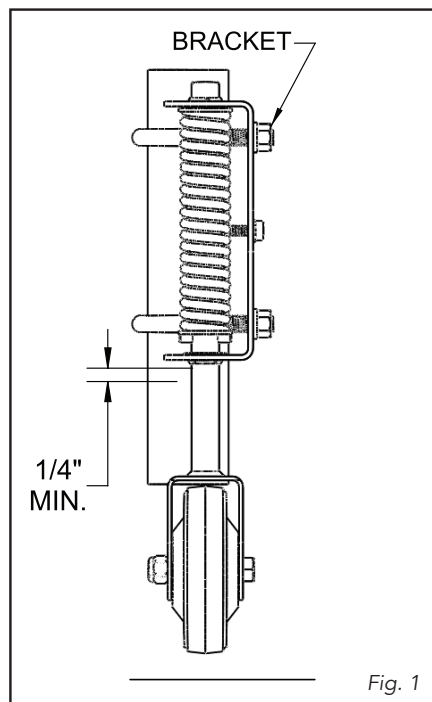

GW3 CHAIN LINK GATE WHEEL



SCAN FOR MORE
INFORMATION

CHANGING MOUNTING INSTRUCTIONS:

1. Manually compress spring and remove the stem pin. If the stem pin is not easily removed, use a hammer and punch and lightly tap the stem pin out of the wheel stem.
Note: take care not to de-form the stem pin during removal.
2. Slide wheel stem out of the bracket. If possible, hold spring and washers in place.
3. Rotate bracket 180 degrees and re-assemble.
4. Compress spring and re-install stem pin and mount Gate Wheel as instructed.

