

PART #	COLOR	SCREWS
CH090-4D-BK	BLACK	(16) #10 X 1" HEX WASHER HD SD SCREWS - MATERIAL: 410 SERIES SS

		REVISIONS		
ECR/DCR	REV.	DESCRIPTION	DATE	APPD
-	-	INITIAL RELEASE	12-13-13	-
DCR-0275	1	REVISED SD SCREW MATERIAL FROM 18-8 SS TO 400 SERIES SS	06-13-14	CGS
-	2	UPDATED TABLE	05-21-24	DDC

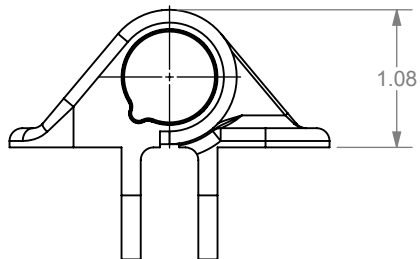
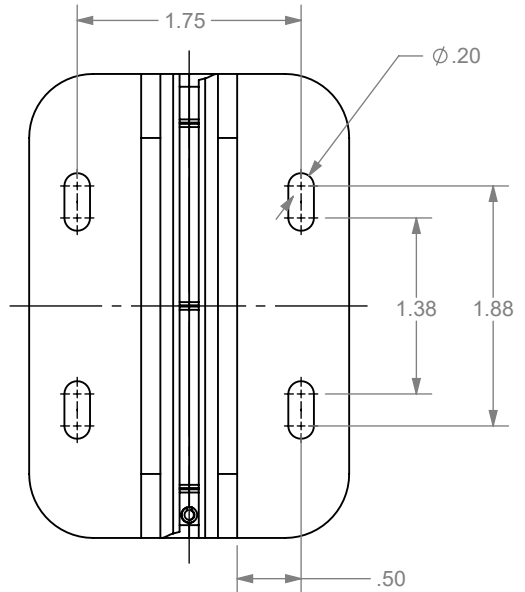
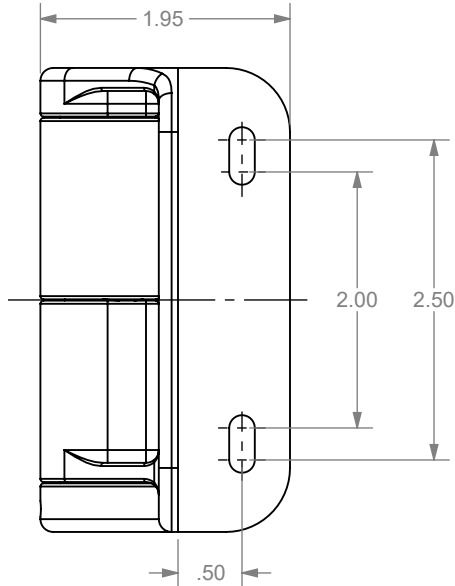
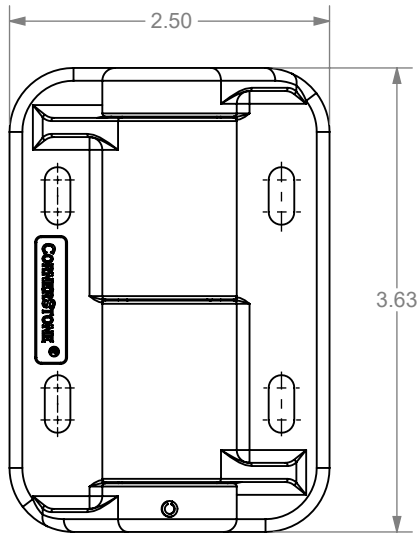
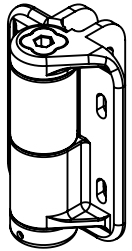
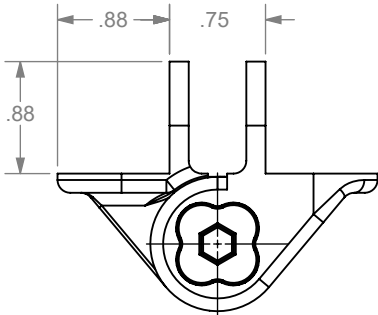

PACKAGING INSTRUCTIONS

POLYBAG CONTAINING:

- (2) HINGES
- (1) ADJUSTMENT WRENCH
- (1) INSTRUCTION SHEET
- (1) WARRANTY SHEET
- (1) POLYBAGGED SCREW PACK (SEE TABLE)

DIMENSIONS ARE IN INCHES TOLERANCES: FRACTIONAL $\pm 1/16"$ ANGULAR: MACH $\pm 1^\circ$ BEND $\pm 1^\circ$ TWO PLACE DECIMAL ± 0.01 THREE PLACE DECIMAL ± 0.005		NATIONWIDE INDUSTRIES®	
PROPRIETARY AND CONFIDENTIAL THE INFORMATION CONTAINED IN THIS DRAWING IS THE SOLE PROPERTY OF NATIONWIDE INDUSTRIES. ANY REPRODUCTION IN PART OR AS A WHOLE WITHOUT THE WRITTEN PERMISSION OF NATIONWIDE INDUSTRIES IS PROHIBITED.		ORNAMENTAL PLASTIC SELF-CLOSING HINGE	
SIZE A	DWG. NO. CS--CH090	REV. 2	SHEET 1 OF 1

PART #	COLOR
KLTRV-200-BK	BLACK

		REVISIONS		
ECR/DCR	REV.	DESCRIPTION	DATE	APPD
-	-	INITIAL RELEASE	05-21-24	DDC

PACKAGING INSTRUCTIONS

POLYBAG CONTAINING:

- (1) LATCH ASSEMBLY
- (1) KEEPER ASSEMBLY
- (1) INSTRUCTION SHEET
- (1) WARRANTY SHEET

- POLYBAG CONTAINING:

- (4) #8 X 1" PAN HD PHILLIPS SD SCREWS - MATERIAL: 410 SS
- (4) #8 X 1" FLAT HD PHILLIPS SD SCREWS - MATERIAL: 410 SS

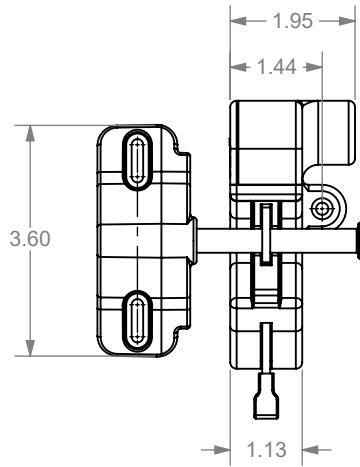
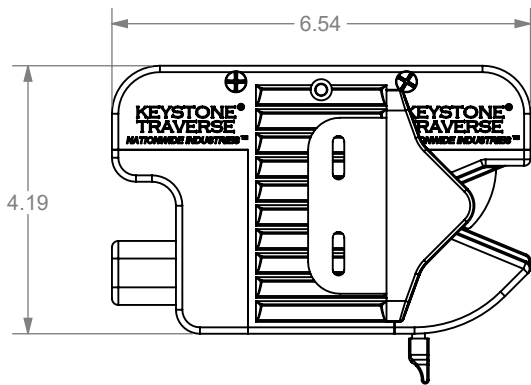
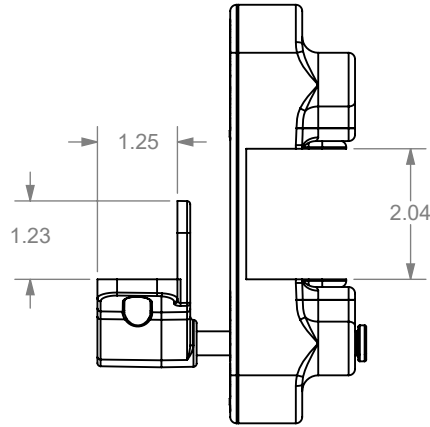
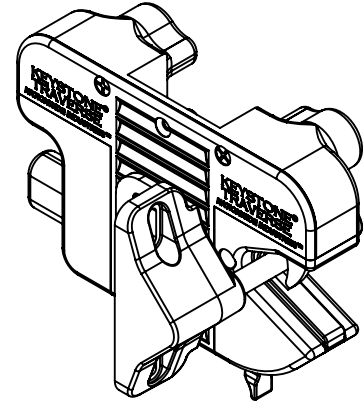

DIMENSIONS ARE IN INCHES
TOLERANCES:
FRACTIONAL $\pm 1/16$ "
ANGULAR: MACH ± 1 " BEND ± 1 "
TWO PLACE DECIMAL ± 0.01
THREE PLACE DECIMAL ± 0.005

PROPRIETARY AND CONFIDENTIAL
THE INFORMATION CONTAINED IN THIS DRAWING IS THE SOLE PROPERTY OF NATIONWIDE INDUSTRIES. ANY REPRODUCTION IN PART OR AS A WHOLE WITHOUT THE WRITTEN PERMISSION OF NATIONWIDE INDUSTRIES IS PROHIBITED.

NATIONWIDE INDUSTRIES®

**KEYSTONE® TRAVERSE
2-SIDED LOCKING LATCH
2"**

SIZE A	DWG. NO. CS--KLTRV-200	REV. -
SCALE: 1:3	WEIGHT:	SHEET 1 OF 1