

KEYSTONE® LOCKLESS LEVER LATCH

NW6254NL-BK



SCAN FOR MORE
INFORMATION

INSTALLATION

STEP 1:

1. Mark the side of the gate frame with a horizontal line at the desired height of the latch handle (Fig. 1). Use of a level is recommended.
2. Place the template so the triangular locating notch (Fig. 2) is centered on the line and the "NATIONWIDE INDUSTRIES" label is on the front of the gate (Fig. 1).
3. Using a pencil, mark the holes on the side labeled "1/8 FRONT" as well as the "1/8" & "5/8" hole locations on the front of the gate.
4. Reverse the template so that the "triangular locating notch" is still located on the line but the "NATIONWIDE INDUSTRIES" label is on the back side of the gate.
5. Using a pencil, mark the hole on the side labeled "1/8 BACK" as well as the "1/8" & "5/8" center hole on the back side of the gate (for the handle spindle).
6. Drill a $\phi 5/8"$ hole at the "5/8" center mark (handle spindle location) on the front and back of the gate (Fig. 3).
7. Drill small pilot holes, $\phi 1/8"$ maximum, at each of the remaining hole locations.

Note: Make sure that the holes are straight and level.

STEP 2:

1. The Keystone® Lever Latch is designed to fit many different gate sizes. Select the gate thickness from Table 1 and determine the required spindle tube length. Select the supplied spindle tube, and if required, trim the spindle tube to be $3/4"$ longer than the gate thickness.

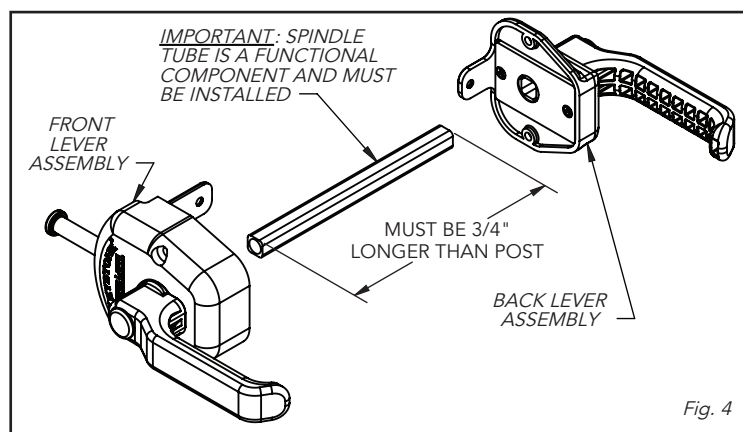
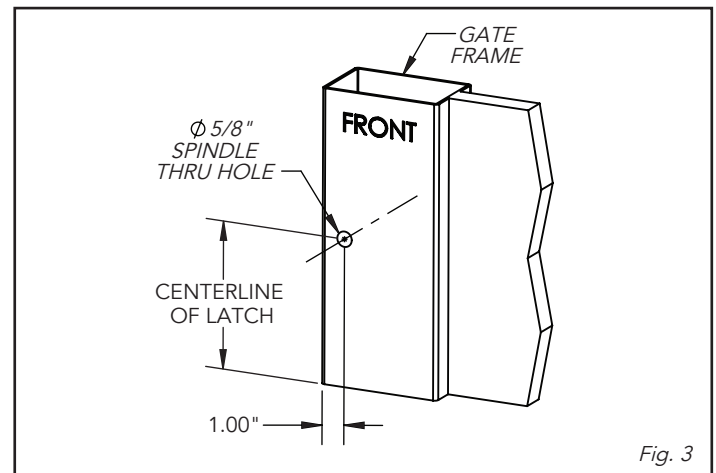
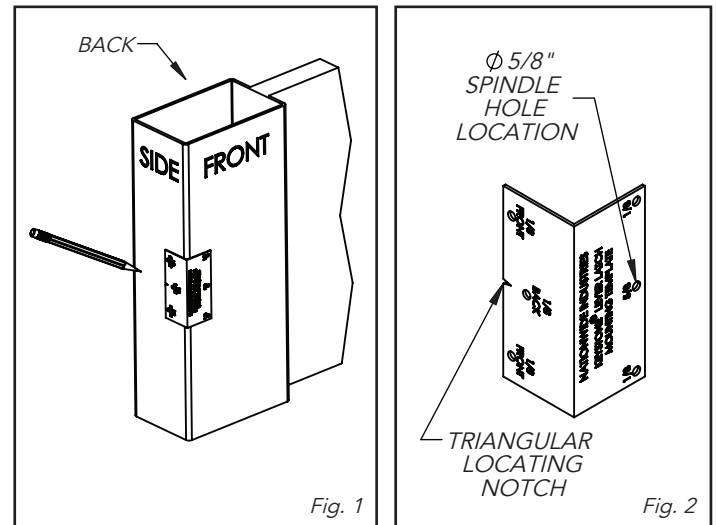

GATE SIZE CHART	
GATE THK.	SPINDLE TUBE LENGTH
1-1/2"	2-1/4"
1-3/4"	2-1/2"*
2"	2-3/4"*
3"	3-3/4"
3-1/2"	4-1/4"
4"	4-3/4"*
5"	5-3/4"*

*SPINDLE TUBE OF THIS LENGTH SUPPLIED IN PACKAGE.

Table 1

KEYSTONE® LOCKLESS LEVER LATCH

NW6254NL-BK



STEP 3:

1. Slide the spindle tube into the back lever assembly approximately 3/8" (Fig. 4).
2. From the back side of the gate, slide the back lever assembly through the 5/8" hole in the gate (Fig. 5). Mount using the supplied mounting screws.

Note: The spindle tube should protrude approximately 3/8" through the opposite side of the gate.

STEP 4:

1. Mount the front lever assembly to front of the gate (Fig. 6). The protruding 3/8" portion of the spindle tube should insert into the front lever assembly.
2. The front lever assembly must sit flush on the front and side of the gate. Mount using the supplied mounting screws.
3. Actuate the handle to ensure a smooth operation.

STEP 5:

1. Place the keeper bracket on the fence post and align with the latch pin (Figure 6). The latch pin must have a minimum 1/8" gap from the bottom of the keeper bracket. Mark the location of the keeper mounting holes. Mount the keeper bracket using the supplied mounting screws.
2. Close the gate to ensure the lever latch is operating properly. Once closed, the latch pin should engage the keeper bracket, but not rest on it.
3. Actuating the handle should disengage the latch. If the latch pin does not clear the keeper bracket, it should be adjusted accordingly.

MAINTENANCE

1. Periodically clean with a mild detergent.

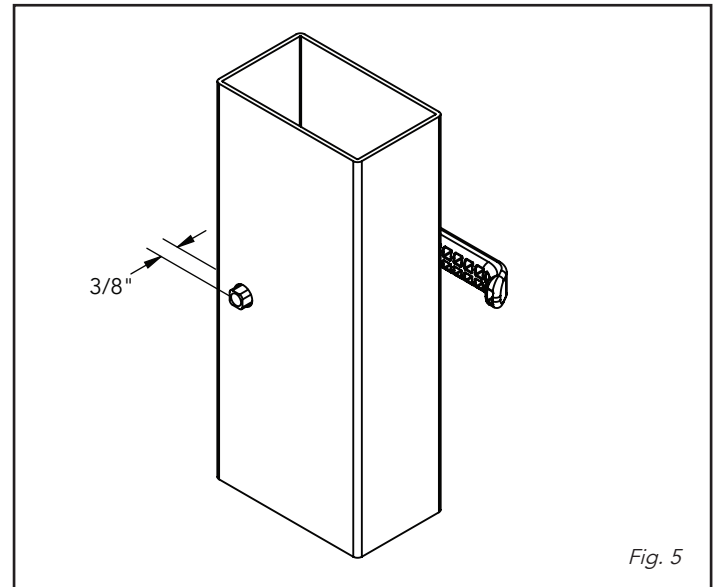

Fig. 5

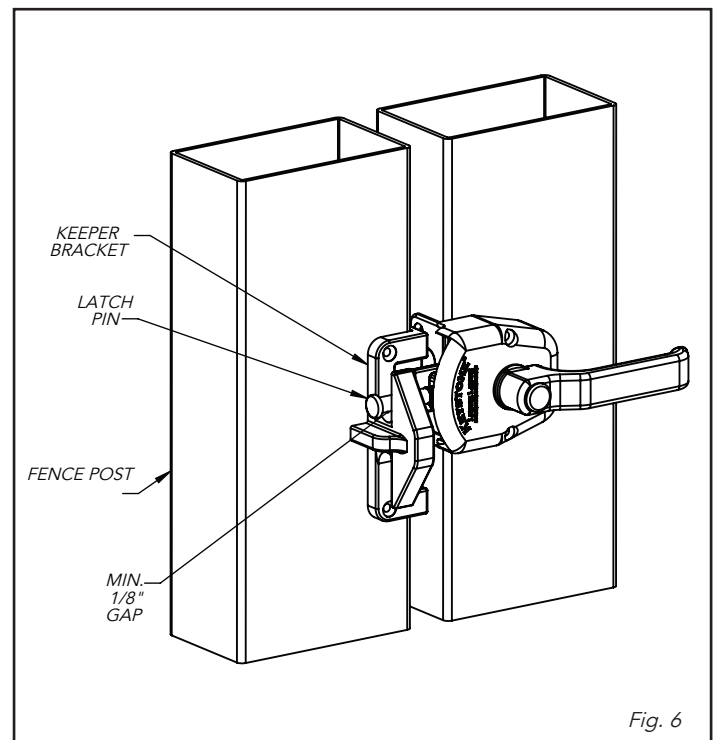

Fig. 6